



KERN & Sohn GmbH

Ziegelei 1

D-72336 Balingen

E-Mail: info@kern-sohn.com

Tel: +49-[0]7433- 9933-0

Fax: +49-[0]7433-9933-149

Internet: www.kern-sohn.com

Operation instructions Platform/floor scales

KERN EOB/EOE/EOS/BOBP

Version 2.3

09/2008

GB



EOB/EOE/EOS/BOBP-BA-e-0823



KERN EOB/EOE/EOS/BOBP

Version 2.3 09/2008

Operation instructions

Platform/floor scales

Table of contents:

1	Technical data	4
2	Declaration of conformity	12
3	Appliance Overview	13
4	Fundamental information (general)	15
4.1	Intended use	15
4.2	Inappropriate use	15
4.3	Guarantee	15
4.4	Monitoring the test substances.....	16
5	Fundamental safety information	16
5.1	Observe the information in the operating instructions.....	16
5.2	Staff training	16
6	Transport and storage	16
6.1	Acceptance check	16
6.2	Packaging.....	16
7	Unpacking, installation and commissioning.....	17
7.1	Place of installation, place of use	17
7.2	Installation.....	18
7.2.1	Unpacking the Balance.....	18
7.2.2	Package volume	18
7.2.3	Mounting instructions for using wall bracket.....	19
7.3	Mains supply	19
7.4	Battery Operation	19
7.5	Initial start-up.....	20
7.6	Adjustment.....	20
7.7	Adjusting	20
8	Operation	21
8.1	Weighing	21
8.2	Taring (TARE key).....	21
8.3	Hold function (Animal weighing function)	22
8.4	Plus / Minus Weighings.....	22

8.5	Weight units	22
9	<i>Maintenance, upkeep, disposal</i>	23
9.1	Cleaning	23
9.2	Maintenance, upkeep	23
9.3	Disposal.....	23
10	<i>Troubleshooting</i>	24

1 Technical data

KERN	EOB 6K5N	EOB 15K10N	EOB 35K20N	EOB 60K50N
<i>Readout (d)</i>	5 g	10 g	20 g	50 g
<i>Weighing range (Max)</i>	6 kg	15 kg	35 kg	60 kg
<i>Reproducibility</i>	5 g	10 g	20 g	50 g
<i>Linearity</i>	10 g	20 g	40 g	100 g
<i>Recommended adjusting weight, not included (class)</i>	5 kg (M3)	10 kg (M3)	20 kg (M3)	40 kg (M3)
<i>Stabilisation time (typical)</i>	2 - 3 sec.			
<i>Optimal temp. of operation</i>	+ 10° C + 35° C			
<i>Humidity</i>	max. 80 % (non-condensing)			
<i>Size (W x D x H) mm</i>	310 x 300 x 55 (platform) 210 x 110 x 45 (terminal)		310 x 300 x 55 (platform) 210 x 110 x 45 (terminal)	
<i>Weighing plate mm</i>	310 x 300			
<i>Weight kg (net)</i>	4			

KERN	EOB 60K50NL	EOB 150K100N	EOB 150K100NL	EOB 150K100NXL
<i>Readout (d)</i>	50 g	100 g	100 g	100 g
<i>Weighing range (Max)</i>	60 kg	150 kg	150 kg	150 kg
<i>Reproducibility</i>	50 g	100 g	100 g	100 g
<i>Linearity</i>	100 g	200 g	200 g	200 g
<i>Recommended adjusting weight, not included (class)</i>	40 kg (M3)	100 kg (M3)	100 kg (M3)	100 kg (M3)
<i>Stabilisation time (typical)</i>	2 – 3 sec.			
<i>Optimal temp. of operation</i>	+ 10° C + 35°			
<i>Humidity</i>	max. 80 % (non-condensing)			
<i>Size (W x D x H) mm</i>	<i>platform:</i> 550 x 550 x 65 <i>terminal:</i> 210 x 110 x 45	<i>platform:</i> 310 x 300 x 55 <i>terminal:</i> 210 x 110 x 45	<i>platform:</i> 550 x 550 x 65 <i>terminal:</i> 210 x 110 x 45	<i>platform:</i> 945 x 505 x 65 <i>terminal:</i> 210 x 110 x 45
<i>Stainless steel weighing plate (mm)</i>	550 x 550	310 x 300	550 x 550	945 x 505
<i>Weight kg (net)</i>	15	4	15	22,0

KERN	EOB 300K100N	EOB 300K200NL	EOB 300K200NXL
<i>Readout (d)</i>	100 g	200 g	200 g
<i>Weighing range (Max)</i>	300 kg	300 kg	300 kg
<i>Reproducibility</i>	100 g	200 g	200 g
<i>Linearity</i>	200 g	400 g	400 g
<i>Recommended adjusting weight, not included (class)</i>	200 kg (M2)	200 kg (M3)	200 kg (M3)
<i>Stabilisation time (typical)</i>	2 - 3 sec.		
<i>Optimal temp. of operation</i>	+ 10° C + 30° C		
<i>Humidity</i>	max. 80 % (non-condensing)		
<i>Size (W x D x H) mm</i>	<i>platform:</i> 310 x 300x 55 <i>terminal:</i> 210 x 110 x 45	<i>platform:</i> 550 x 550 x 65 <i>terminal:</i> 210 x 110 x 45	<i>platform:</i> 945 x 505 x 65 <i>terminal:</i> 210 x 110 x 45
<i>Stainless steel weighing plate (mm)</i>	310 x 300	550 x 550	945 x 505
<i>Weight kg (net)</i>	4	15	22,0

KERN	EOE 6K5	EOE 15K10	EOE 35K20	EOE 60K50
<i>Readout (d)</i>	5 g	10 g	20 g	50 g
<i>Weighing range (Max)</i>	6 kg	15 kg	35 kg	60 kg
<i>Reproducibility</i>	5 g	10 g	20 g	50 g
<i>Linearity</i>	10 g	20 g	40 g	100 g
<i>Recommended adjusting weight, not included (class)</i>	5 kg (M3)	10 kg (M3)	20 kg (M3)	40 kg (M3)
<i>Stabilisation time (typical)</i>	2 - 3 sec.			
<i>Optimal temp. of operation</i>	+ 10° C + 35° C			
<i>Humidity</i>	max. 80 % (non-condensing)			
<i>Size (W x D x H) mm</i>	210 x 110 x 45			
<i>Weighing plate (mm)</i>	310 x 300	310 x 300	310 x 300	310 x 300
<i>Weight kg (net)</i>	4	4	4	4

KERN	EOE 150K50L	EOE 150K50XL	EOE 150K100	EOE 150K100L	EOE 150K100XL
<i>Readout (d)</i>	50 g	50 g	100 g	100 g	100 g
<i>Weighing range (Max)</i>	150 kg	150 kg	150 kg	150 kg	150 kg
<i>Reproducibility</i>	50 g	50 g	100 g	100 g	100 g
<i>Linearity</i>	100 g	100 g	200 g	200 g	200 g
<i>Recommended adjusting weight, not included (class)</i>	100 kg (M3)	100 kg (M3)	100 kg (M3)	100 kg (M3)	100 kg (M3)
<i>Stabilisation time (typical)</i>	2 - 3 sec.				
<i>Optimal temp. of operation</i>	+ 10° C + 35° C				
<i>Humidity</i>	max. 80 % (non-condensing)				
<i>Size (W x D x H) mm</i>	210 x 110 x 45				
<i>Weighing plate (mm)</i>	505 x 505	505 x 505	310 x 300	505 x 505	945x505
<i>Weight kg (net)</i>	14	20	4	14	22

KERN	EOE 300K100L	EOE 300K100XL	EOE 300K200L	EOE 300K200XL
<i>Readout (d)</i>	100 g	100 g	200 g	200 g
<i>Weighing range (Max)</i>	300 kg	300 kg	300 kg	300 kg
<i>Reproducibility</i>	100 g	100 g	200 g	200 g
<i>Linearity</i>	200 g	200 g	400 g	400 g
<i>Recommended adjusting weight, not included (class)</i>	200 kg (M3)	200 kg (M3)	200 kg (M3)	200 kg (M3)
<i>Stabilisation time (typical)</i>	2 - 3 sec.			
<i>Optimal temp. of operation</i>	+ 10° C + 35° C			
<i>Humidity</i>	max. 80 % (non-condensing)			
<i>Size (W x D x H) mm</i>	210 x 110 x 45			
<i>Stainless steel weighing plate (mm)</i>	505 x 505	945x505	505 x 505	945 x 505
<i>Weight kg (net)</i>	14	22	14	22,0

KERN	EOS 150K100NXL	EOS 300K200NXL
<i>Readout (d)</i>	100 g	200g
<i>Weighing range (Max)</i>	150 kg	300kg
<i>Reproducibility</i>	100 g	200 g
<i>Linearity</i>	200 g	400 g
<i>Recommended adjusting weight, not included (class)</i>	100 kg (M3)	200 kg (M3)
<i>Stabilisation time (typical)</i>	2 - 3 sec.	
<i>Optimal temp. of operation</i>	+ 10° C + 35° C	
<i>Humidity</i>	max. 80 % (non-condensing)	
<i>Size (W x D x H) mm</i>	900 x 550 x 65 (plattform) 210 x 110 x 45 (terminal)	
<i>Stainless steel weighing plate (mm)</i>	900 x 550 x 65	
<i>Weight kg (net)</i>	22,5	

KERN	BOBP 300K200	BOBP 750K500	BOBP 1.5T1
<i>Readout (d)</i>	200 g	500 g	1000g
<i>Weighing range (Max)</i>	300 kg	750 kg	1500kg
<i>Reproducibility</i>	200 g	500 g	1000g
<i>Linearity</i>	400 g	1000 g	2000g
<i>Recommended adjusting weight, not included (class)</i>	200 kg (M3)	500 kg (M3)	1t(M3)
<i>Stabilisation time (typical)</i>	2 - 3 sec.		
<i>Optimal temp. of operation</i>	+ 5° C + 35° C		
<i>Humidity</i>	max. 80 % (nicht kondensierend)		
<i>Size (W x D x H) mm</i>	1006x996x90 (Plattform) 210 x 110 x 45 (Terminal)		
<i>Weight kg (net)</i>	50,5		

2 Declaration of conformity



KERN & Sohn GmbH

D-72322 Balingen-Frommern

Postfach 4052

E-Mail: info@kern-sohn.de

Tel: 0049-[0]7433- 9933-0

Fax: 0049-[0]7433-9933-149

Internet: www.kern-sohn.de

Konformitätserklärung

Declaration of conformity for apparatus with CE mark

Konformitätserklärung für Geräte mit CE-Zeichen

Déclaration de conformité pour appareils portant la marque CE

Declaración de conformidad para aparatos con disitintivo CE

Dichiarazione di cofnromità per apparecchi contrassegnati con la marcatura CE

- English** We hereby declare that the product to which this declaration refers conforms with the following standards.
- Deutsch** Wir erklären hiermit, dass das Produkt, auf das sich diese Erklärung bezieht, mit den nachstehenden Normen übereinstimmt.
- Français** Nous déclarons avec cela responsabilité que le produit, auquel se rapporte la présente déclaration, est conforme aux normes citées ci-après.
- Español** Manifestamos en la presente que el producto al que se refiere esta declaración est´a de acuerdo con las normas siguientes
- Italiano** Dichiariamo con ciò che il prodotto al quale la presente dichiarazione si riferisce è conforme alle norme di seguito citate.

Platform Scale: KERN EOB/EOE/EOS/BOBP

Mark applied	EU Directive	Standards
	89/336EEC EMC	EN 61000-6-3 : 2001+A11 :2004 EN 61000-6-1 : 2001

Date: 17. Nov. 2006

Signature: 

Gottl. KERN & Sohn GmbH
Management

Gottl. KERN & Sohn GmbH, Ziegelei 1, D-72336 Balingen, Tel. +49-[0]7433/9933-0, Fax +49-[0]7433/9933-149

3 Appliance Overview

EOB models, stainless steel weighing plate



**EOB models with stand (option),
only models with weighing plate 310 x 300**



EOE models, weighing plate, lacquered



EOS models, Stainless steel weighing plate



BOBP models



4 Fundamental information (general)

4.1 Intended use

The balance you have acquired serves to determine the weighing value of the material to be weighed. It is intended to be used as a “non-automatic” balance, i.e. the material to be weighed is manually and carefully placed in the centre of the weighing plate. The weighing value can be read off after a stable weighing value has been obtained.

4.2 Inappropriate use

Do not use the balance for dynamic weighing. In the event that small quantities are removed or added to the material to be weighed, incorrect weighing results can be displayed due to the “stability compensation” in the balance. (Example: Slowly draining fluids from a container on the balance.)

Do not leave a permanent load on the weighing plate. This can damage the measuring equipment.

Be sure to avoid impact shock and overloading the balance in excess of the prescribed maximum load rating (max.), minus any possible tare weight that is already present. This could cause damage to the balance.

Never operate the balance in hazardous locations. The series design is not explosion-proof.

Structural alterations may not be made to the balance. This can lead to incorrect weighing results, faults concerning safety regulations as well as to destruction of the balance.

The balance may only be used in compliance with the described guidelines. Varying areas of application/planned use must be approved by KERN in writing.

4.3 Guarantee

The guarantee is not valid following

- non-observation of our guidelines in the operating instructions
- use outside the described applications
- alteration to or opening of the device
- mechanical damage and damage caused by media, liquids
- natural wear and tear
- inappropriate erection or electric installation
- overloading of the measuring equipment

4.4 Monitoring the test substances

The metrology features of the balance and any possible available adjusting weight must be checked at regular intervals within the scope of quality assurance. For this purpose, the answerable user must define a suitable interval as well as the nature and scope of this check. Information is available on KERN's home page (www.kern-sohn.com) with regard to the monitoring of balance test substances and the test weights required for this. Test weights and balances can be adjusted quickly and at a reasonable price in KERN's accredited DKD calibration laboratory (return to national normal).

5 Fundamental safety information

5.1 Observe the information in the operating instructions

Please read the operating instructions carefully before erecting and commissioning, even if you already have experience with KERN balances.

5.2 Staff training

The device may only be operated and looked after by trained members of staff.

6 Transport and storage

6.1 Acceptance check

Please check the packaging immediately upon delivery and the device during unpacking for any visible signs of external damage.

6.2 Packaging

Please retain all parts of the original packaging in case it should be necessary to return items at any time.

Only the original packaging should be used for return consignments.

Before despatch, disconnect all attached cables and loose/movable parts.

7 Unpacking, installation and commissioning

7.1 Place of installation, place of use

The balance is constructed in such a way that reliable weighing results can be achieved under normal application conditions.

By selecting the correct location for your balance, you will be able to work quickly and precisely.

Therefore please observe the following at the place of installation:

- Place the balance on a firm, level surface;
- Avoid extreme heat as well as temperature fluctuation caused by installing next to a radiator or in the direct sunlight;
- Protect the balance against direct draughts due to open windows and doors;
- Avoid jarring during weighing;
- Protect the balance against high humidity, vapours and dust;
- Do not expose the device to extreme dampness for longer periods of time. Inadmissible bedewing (condensation of air moisture on the device) can occur if a cold device is taken into a significantly warmer environment. In this case, please acclimatise the device for approx. 2 hours at room temperature after it has been disconnected from the mains.
- Avoid static charging of the material to be weighed, weighing container and windshield.

Major display deviations (incorrect weighing results) are possible if electromagnetic fields occur as well as due to static charging and instable power supply. It is then necessary to change the location.

7.2 Installation

Install the balance in such a fashion that the weighing plate is absolutely horizontal.

7.2.1 Unpacking the Balance

Carefully remove the balance from the packaging and out of the plastic covering, then place the balance on the assigned position.

7.2.2 Package volume

Serial fittings:

KERN EOB

- Platform (stainless steel weighing plate) and display device
- 4 x Adjusting feet (except platform 310 x 300)
- Mains device
- Wall bracket (with anchoring screws)
- Operating instructions

KERN EOE

- Platform and display device
- 4 x Adjusting feet
- Mains device
- Wall bracket (with anchoring screws)
- Operating instructions

KERN EOS

- Platform (stainless steel weighing plate) and display device
- 4 x Adjusting feet
- Mains device
- Rubber mat
- Wall bracket (with anchoring screws)
- Operating instructions

KERN BOBP

- Platform and display device
- 4 x Adjusting feet
- Mains device
- Wall bracket (with anchoring screws)
- Operating instructions

7.2.3 Mounting instructions for using wall bracket

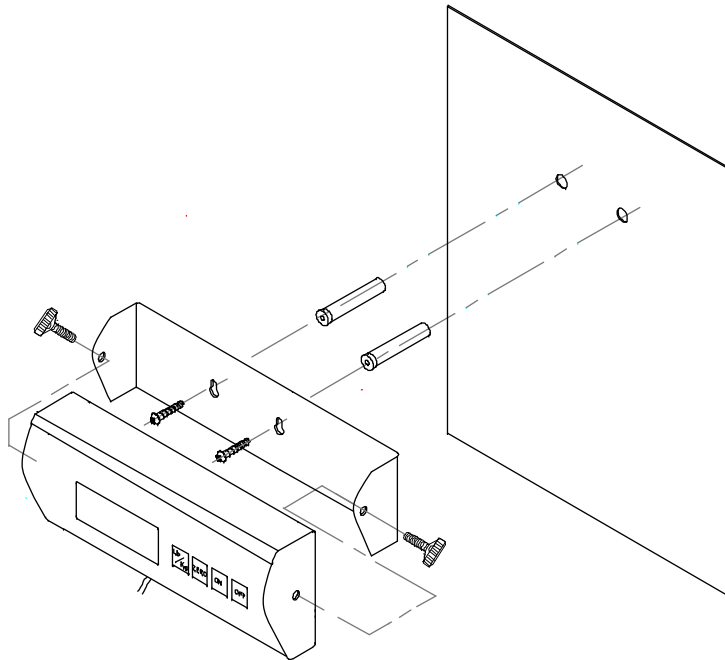

7.3 Mains supply

Electric power supply is by means of the external mains supply circuit. The printed voltage level must comply with the local voltage. Only use original KERN mains supply circuits. The use of other makes is subject to approval by Kern.

7.4 Battery Operation

Remove the battery cover underneath the display. Connect 6 x 1,5V round cells. Reinsert the battery cover.

Battery conservation through automatic power-off 3 minutes after ending a weighing operation.

When the battery power is used up the display will show "LO". Press the **OFF** key and change the batteries at once.

When the balance is not in use for a longer period of time remove batteries and keep them separately. Leakage of battery liquid might damage the balance.

7.5 Initial start-up

A warm-up time of 5 minutes stabilises the measured values after switching on.

The accuracy of the balance depends on the local acceleration of the fall. Please be sure to observe the information in the chapter on adjusting.

7.6 Adjustment

As the acceleration value due to gravity is not the same at every location on earth, each balance must be coordinated – in compliance with the underlying physical weighing principle - to the existing acceleration due to gravity at its place of location (only if the balance has not already been adjusted to the location in the factory). This adjustment process must be carried out during the initial start-up, after change in location and variation of surrounding temperature. It is also recommendable to adjust the balance periodically during weighing operation in order to obtain exact measured values

7.7 Adjusting

Balance accuracy can be checked and adjusted at any time using an adjusting weight.

Method of adjusting:

Observe stable ambience conditions. A short warming-up time of approx. 5 minutes for stabilisation purposes is useful.

Press **UNIT** key and hold depressed until the exact size of the adjusting weight flashes on the display panel, "Load" appears on the display panel alternately. Place the adjusting weight in the centre of the weighing plate. Press **UNIT** key. The value of the size of the adjusting weight will stabilise a short time later.

Keep the adjusting weight next to the balance. A daily balance accuracy check is recommended for applications relevant to quality.

8 Operation

8.1 Weighing

Switch the balance on by pressing the **ON/** key.

The balance will show “88888” for approx. 3 seconds and then change to “0”. Now it is ready for use.

Important: If the display does not show “0” press the TARE key.

Only now (!) place object on the weighing pan. Make sure that the weighing object does not strike or touch the housing or base.

Now the weight will be indicated.

If the object should be heavier than the weighing range allowance, the symbol Err(overload) will appear on the display.

8.2 Taring (TARE key)

Switch the balance on by pressing the **ON** key, then wait for the “0” indication.

Place the jiffy on the weighing pan and press the **TARE** key. Display again shows “0”. Now the weight of the jiffy is memorised internally.

By pressing the **TARE** key after a weighing procedure, “0” will appear on the display again.

The taring procedure can be repeated continuously, for instance when mixing several components.

The limit is reached when the full weighing range is overlaid.

After having removed the jiffy the total weight will appear as a minus indication.

8.3 Hold function (Animal weighing function)

The balance has an integrated animal weighing function (mean value) with which it is possible to weigh small or domestic animals (minimum weight 1% of max.) precisely, even when they do not stand still on the weighing platform.

Remark: With too lively movement (strong display fluctuation) no mean value can take place.

Place the animal to be weighed on the weighing platform and press the **HOLD** key. A triangle will start to flash on the left hand side of the display, and during this time the balance will record several values, then calculate and display an mean value. By pressing the **HOLD** key again, the weighing machine will be reset to standard weighing mode.

By pressing the **HOLD** key again, this function can be repeated as often as desired.

8.4 Plus / Minus Weighings

For instance to control piece-weights, filling process control etc.

Switch the balance on by pressing the **ON** key, then wait until "0" is indicated.

Place rated weight on the weighing pan and tare on "0" by pressing the **TARE** key. Remove rated weight.

Place the objects on the weighing pan successively, the balance will show any deviation from the rated weight in "+" and "-".

According to the same procedure packages with the same weight, related to a rated weight, can be produced.

Return to the weighing mode by pressing the **TARE** key.

8.5 Weight units

Two units are available: "kg" and "lb".

The weight unit is chosen by pressing the "**Unit**" key.

A lamp to the right of the display signalises the respective unit.

Unit conversion: **1 kg = 2.20462 lb**

9 Maintenance, upkeep, disposal

9.1 Cleaning

Please disconnect the device from the operating voltage before cleaning.

Only use a cloth dampened with mild suds and not aggressive cleaning agents (solvents or similar). Please ensure that fluids are not able to get into the device and rub off using a clean, soft cloth.

Loose sample residue/powder can be removed carefully using a brush or hand vacuum cleaner.

Remove any spilt material to be weighed immediately.

9.2 Maintenance, upkeep

The device may only be opened by trained service engineers authorised by KERN. Disconnect from the mains supply before opening.

9.3 Disposal

The operating company shall dispose of the packaging and the device in compliance with the valid national or regional law of the operating location.

10 Troubleshooting

The balance should be switched off for a short time following an interruption in the programme sequence and disconnected from the mains supply. It is then necessary to repeat the weighing process from the beginning.

Help:

Interruption

Possible cause

Weight display is not illuminated.

- *The balance is not switched on.*
- *The mains supply connection has been interrupted (mains cable not plugged in/faulty).*
- *Power supply interrupted. .*

The weight display changes continually

- *Draught/air movement*
- *Table/floor vibrations*
- *The weighing plate is in contact with foreign matter.*
- *Electromagnetic fields / static charging (choose different location/switch off interfering device if possible)*

The weighing result is obviously incorrect

- *The balance display is not set to zero*
- *Adjustment is no longer correct.*
- *Great fluctuations in temperature.*
- *Electromagnetic fields / static charging (choose different location/switch off interfering device if possible)*

Switch the balance off if other error messages should appear and then switch on again. Contact the manufacturer if the error message does not disappear.